

Stainless Steel Installation and Assembly Guide



TABLE OF CONTENT

- Operating Conditions, Safety Instructions & Installations in explosive environments3
- Expansion Loops and Compensators4
- Pipe Support5

- Tools 6-7
 - Overview 6
 - Inspection and maintenance.....7

- Installation..... 8-11
 - Pipe Preparation..... 8
 - Diameters 15 -35 mm / 1/2" - 1 1/4" 9
 - Diameters 42 - 54 mm / 1 1/2" - 2" 10
 - Diameters 76 - 108 mm / 2 3/4" - 4" 11

- Minimum distances and space requirements for pressing 12

OPERATING CONDITIONS & SAFETY INSTRUCTIONS

OPERATING CONDITIONS

AIRnet stainless steel pipes and fittings are designed to convey compressed air and vacuum. The system can also be used for nitrogen, helium, argon, neon, xenon and krypton.

AIRnet stainless steel pipes and fittings must only be used within the pressure and temperature specifications referred to in the AIRnet Stainless Steel Component List.

AIRnet stainless steel pipes and fittings must be appropriately protected against violent impacts and wind gusts.

Ensure accessibility of the AIRnet system for possible future system expansion or maintenance.

AIRnet stainless steel pipes and fittings should not be used as support for electrical equipment or earth conductors.

AIRnet stainless steel pipes should never be directly connected to a source of vibrations (use hoses instead).

Pressure relief valves must be installed where needed to ensure that the system working pressure cannot exceed the maximum working pressure of AIRnet Stainless Steel.

AIRNET INSTALLATIONS IN EXPLOSIVE ENVIRONMENTS

Cutting, deburring and assembly of AIRnet stainless steel pipes can create sparks. Necessary precautions in explosive atmospheres must be taken.

AIRnet stainless steel installations in explosive environments must always be earthed. Bonding and earthing must be checked at frequent intervals to secure that the system cannot be electrically charged.

PURITY REMARKS

To guarantee the purity of the compressed air at the point of use:

- a system purge of at least 24h is highly recommended.
- a properly sized certified point-of-use filter is advised, depending on the application requirements.

AIRnet stainless steel cannot be allowed to convey any end products (food, beverage, pharmaceuticals, etc.)

SAFETY INSTRUCTIONS

Installation, adjustments and repair work of an AIRnet system must be performed by authorized trained personnel.

Installers must use the necessary protection means (PPMs). When working at heights, use a harness for personal protection, and ensure that tools are securely fastened to prevent them from falling.

Installers must comply to all local safety requirements related to the application(s) in scope. Special care must always be taken to prevent suffocation risks when working with gases other than air.

Before any installation, adjustment, repair work or other non-routine checks, relieve the AIRnet system of pressure and effectively isolate the system from all sources of pressure.

Only genuine AIRnet parts should be used when installing, adjusting or repairing an AIRnet stainless steel system.

All plugs and caps must be removed before installing the AIRnet pipes.

Check the surface of the AIRnet pipes before installing. There should be no relevant scratches, abrasions, dents etc.

Use only solvents or chemicals which do not damage the materials of AIRnet.

Before using the AIRnet stainless steel system, installers must ensure that all necessary test controls and applicable rules for the specific installation are complied with.

At initial startup of the AIRnet system, apply a test pressure of 1.5 bar to identify leakage or imperfect joints. After performing an inspection, increase the pressure gradually and constantly (max 1 bar every 30 seconds) and perform a second inspection for leakages or imperfect joints at the final pressure.

EXPANSION LOOPS AND COMPENSATORS

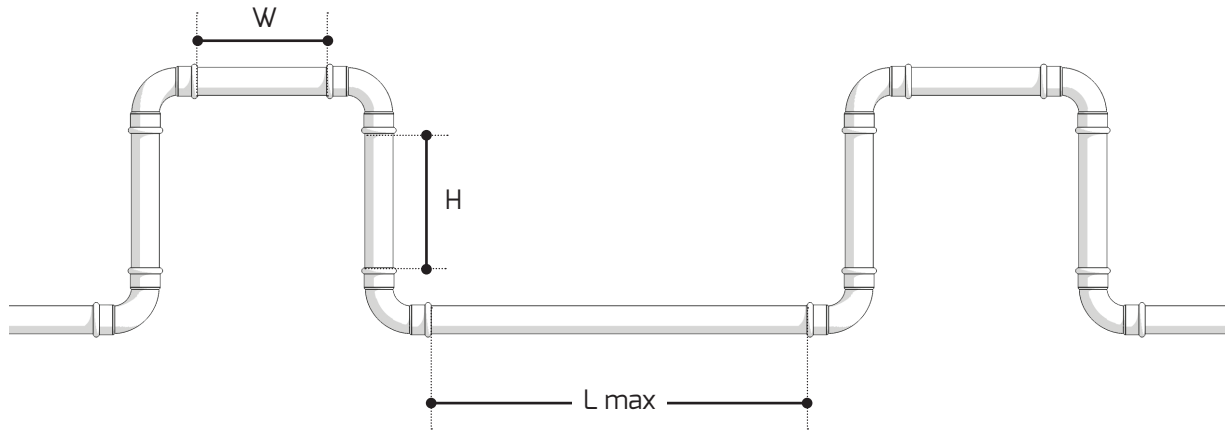

Long straight pipes will expand or contract due to temperature variations. To compensate for this effect, expansion loops or compensators are required. An expansion loop is a U-shaped construction that compensates the variation in length. Compensators are straight fittings specifically designed to allow axial movement. The number of expansion loops / compensators depends on the total length of the straight line and the maximum temperature variation.

The below table gives the maximum possible straight distance between two expansion loops with fixed piping vs. the temperature variation:

	Ø15 mm / 1/2"	Ø28 mm / 1"	Ø35 mm / 1 1/4"	Ø42 mm / 1 1/2"	Ø54 mm / 2"	Ø76 mm / 2 3/4"	Ø89 mm / 3 1/2"	Ø108 mm / 4"
H	0,75 m / 2,5 ft	1 m / 3,3 ft		1,25m / 4,1 ft		1,5 m / 5 ft		1,75 m / 5,75 ft
W	0,375 m / 1,25 ft	0,5 m / 1,6 ft		0,625m / 2 ft		0,75 m / 2,5 ft		0,875 m / 2,9 ft
Δt	Maximim distance between two expansion joints							
5°C / 9°F	726 m / 2383 ft	691 m / 2269 ft	553 m / 1815 ft	720 m / 2364 ft	560 m / 1838 ft	573 m / 1881 ft	489 m / 1606 ft	549 m / 1802 ft
10°C / 18°F	363 m / 1191 ft	345 m / 1134 ft	276 m / 907 ft	360 m / 1182 ft	280 m / 919 ft	286 m / 940 ft	244 m / 803 ft	274 m / 901 ft
20°C / 36°F	181 m / 595 ft	172 m / 567 ft	138 m / 453 ft	180 m / 591 ft	140 m / 459 ft	143 m / 470 ft	122 m / 401 ft	137 m / 450 ft
30°C / 54°F	121 m / 397 ft	115 m / 378 ft	92 m / 302 ft	120 m / 394 ft	93 m / 306 ft	95 m / 313 ft	81 m / 267 ft	91 m / 300 ft
40°C / 72°F	90 m / 297 ft	86 m / 283 ft	69 m / 226 ft	90 m / 295 ft	70 m / 229 ft	71 m / 235 ft	61 m / 200 ft	68 m / 225 ft
50°C / 90°F	72 m / 238 ft	69 m / 226 ft	55 m / 181 ft	72 m / 236 ft	56 m / 183 ft	57 m / 188 ft	48 m / 160 ft	54 m / 180 ft
60°C / 108°F	60 m / 198 ft	57 m / 189 ft	46 m / 151 ft	60 m / 197 ft	46 m / 153 ft	47 m / 156 ft	40 m / 133 ft	45 m / 150 ft
70°C / 126°F	51 m / 170 ft	49 m / 162 ft	39 m / 129 ft	51 m / 168 ft	40 m / 131 ft	40 m / 134 ft	34 m / 114 ft	39 m / 128 ft
80°C / 144°F	45 m / 148 ft	43 m / 141 ft	34 m / 113 ft	45 m / 147 ft	35 m / 114 ft	35 m / 117 ft	30 m / 100 ft	34 m / 112 ft
90°C / 162°F	40 m / 132 ft	38 m / 126 ft	30 m / 100 ft	40 m / 131 ft	31 m / 102 ft	31 m / 104 ft	27 m / 89 ft	30 m / 100 ft
100°C / 180°F	36 m / 119 ft	34 m / 113 ft	27 m / 90 ft	36 m / 118 ft	28 m / 91 ft	28 m / 94 ft	24 m / 80 ft	27 m / 90 ft

EXPANSION LOOPS AND COMPENSATORS

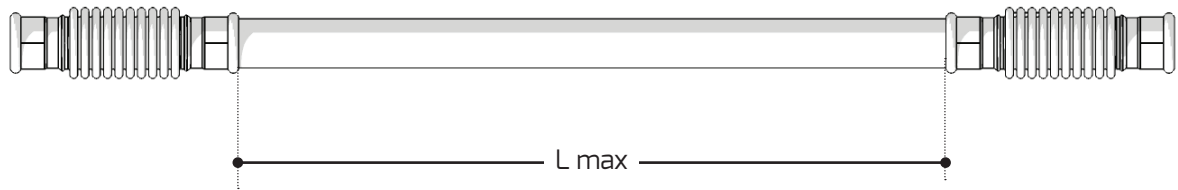

The table below gives the maximum possible straight distance between two compensators vs. the temperature variation:

	Ø15 mm / 1/2"	Ø28 mm / 1"	Ø35 mm / 1 1/4"	Ø42 mm / 1 1/2"	Ø54 mm / 2"
Δt	Maximum distance between two compensators (1000 cycles max.)				
5°C / 9°F	193 m / 636 ft	266 m / 874 ft	315 m / 1033 ft	387 m / 1272 ft	436 m / 1431 ft
10°C / 18°F	96 m / 318 ft	133 m / 437 ft	157 m / 516 ft	193 m / 636 ft	218 m / 715 ft
20°C / 36°F	48 m / 159 ft	66 m / 218 ft	78 m / 258 ft	96 m / 318 ft	109 m / 357 ft
30°C / 54°F	32 m / 106 ft	44 m / 145 ft	52 m / 172 ft	64 m / 212 ft	72 m / 238 ft
40°C / 72°F	24 m / 79 ft	33 m / 109 ft	39 m / 129 ft	48 m / 159 ft	54 m / 178 ft
50°C / 90°F	19 m / 63 ft	26 m / 87 ft	31 m / 103 ft	38 m / 127 ft	43 m / 143 ft
60°C / 108°F	16 m / 53 ft	22 m / 72 ft	26 m / 86 ft	32 m / 106 ft	36 m / 119 ft
70°C / 126°F	13 m / 45 ft	19 m / 62 ft	22 m / 73 ft	27 m / 90 ft	31 m / 102 ft
80°C / 144°F	12 m / 39 ft	16 m / 54 ft	19 m / 64 ft	24 m / 79 ft	27 m / 89 ft
90°C / 162°F	10 m / 35 ft	14 m / 48 ft	17 m / 57 ft	21 m / 70 ft	24 m / 79 ft
100°C / 180°F	9 m / 31 ft	13 m / 43 ft	15 m / 51 ft	19 m / 63 ft	21 m / 71 ft

Example:

Consider an installation with a 100m / 328 ft straight line in 15mm / 1/2" pipe. The minimum temperature of the system is -20°C / -4°F in the winter, and the maximum temperature is 50°C / 122°F due to hot compressed air when the system is in use. The Δt is then 70°C / 126°F.

For this 100m / 328 ft straight line, this means that 1 expansion loop is required. This means that for this straight line, 7 compensators are required.

PIPE SUPPORT

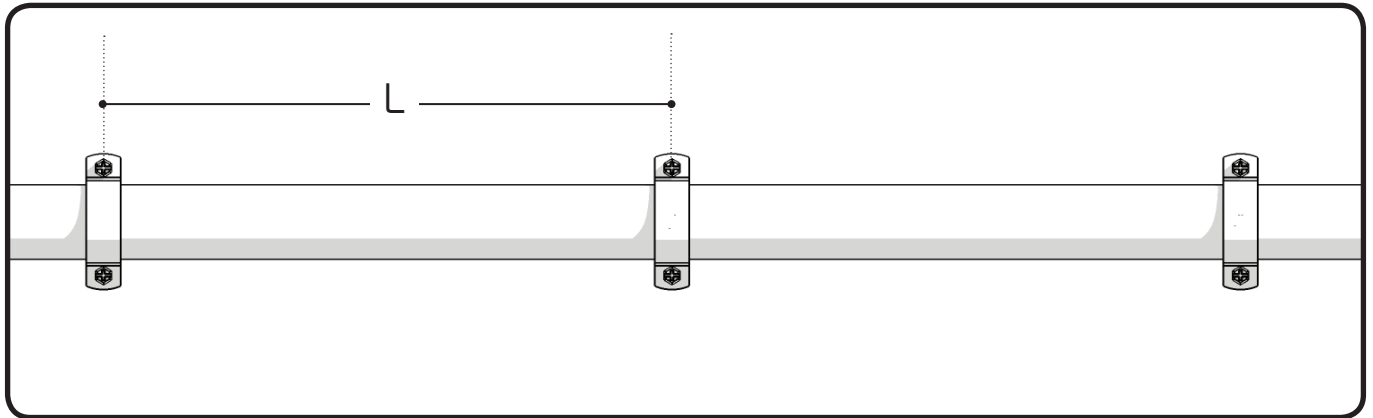

The maximum distance L between two pipe clips is given by the table below:

External Pipe Diameter (mm / inch)	Maximum distance (m / ft)
15 / 1/2"	1,5 / 5
28 / 1"	2,5 / 8
35 / 1 1/4"	2,5 / 8
42 / 1 1/2"	3 / 10
54 / 2"	3,5 / 11,5
76 / 2 3/4"	4 / 13
89 / 3 1/2"	4,5 / 14,5
108 / 4"	5 / 16

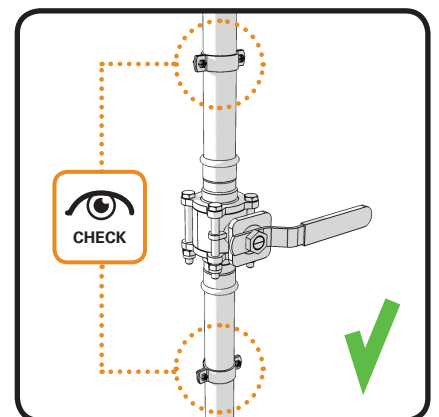

Valves must be supported by a pipe clip on both sides, with a maximum distance of 0.5m (20") between the valve and the pipe clips.

D15 - D35

1/2" - 1 1/4"

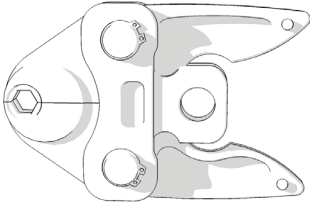

- D15 / 1/2" = 2812 1028 00
- D28 / 1" = 2812 2028 00
- D35 / 1 1/4" = 2812 3028 00

D42 - D54

1 1/2" - 2"

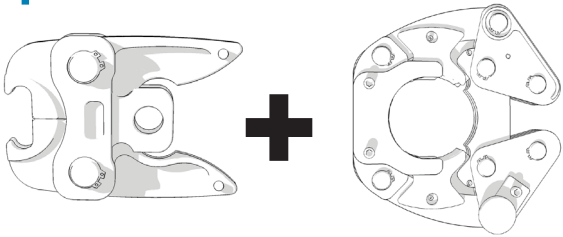

2812 4528 00

- D42 / 1 1/2" = 2812 4028 00
- D54 / 2" = 2812 5028 00

D76 - D108

2 3/4" - 4"

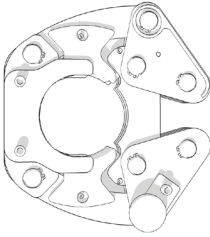

- D76 / 2 3/4" = 2812 6028 00
- D89 / 3 1/2" = 2812 7028 00
- D108 / 4" = 2812 8028 00

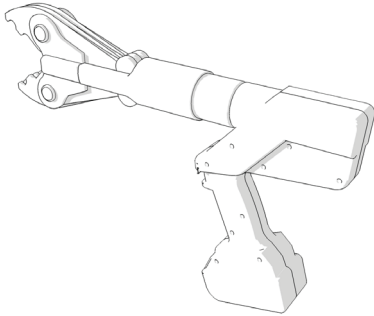
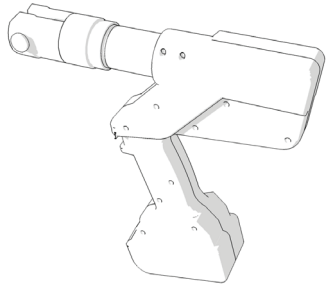

Note: the AIRnet Stainless Steel System will only attain the designed pressure when installed using the tools in the table above. Using other tools is not recommend, as this may lower the pressure rating.

TOOLS - INSPECTION AND MAINTENANCE

To guarantee correct installation, the pressing tools must be checked regularly by an official authorized repairer according to the manufacturer specifications.

All moving parts and pressing surfaces must be cleaned and lubricated daily.

Before starting installation, make sure to inspect the tools thoroughly. Any possible oxidation, paint or dirt will affect the reliability, possibly resulting in sliding issues on the fittings during pressing.

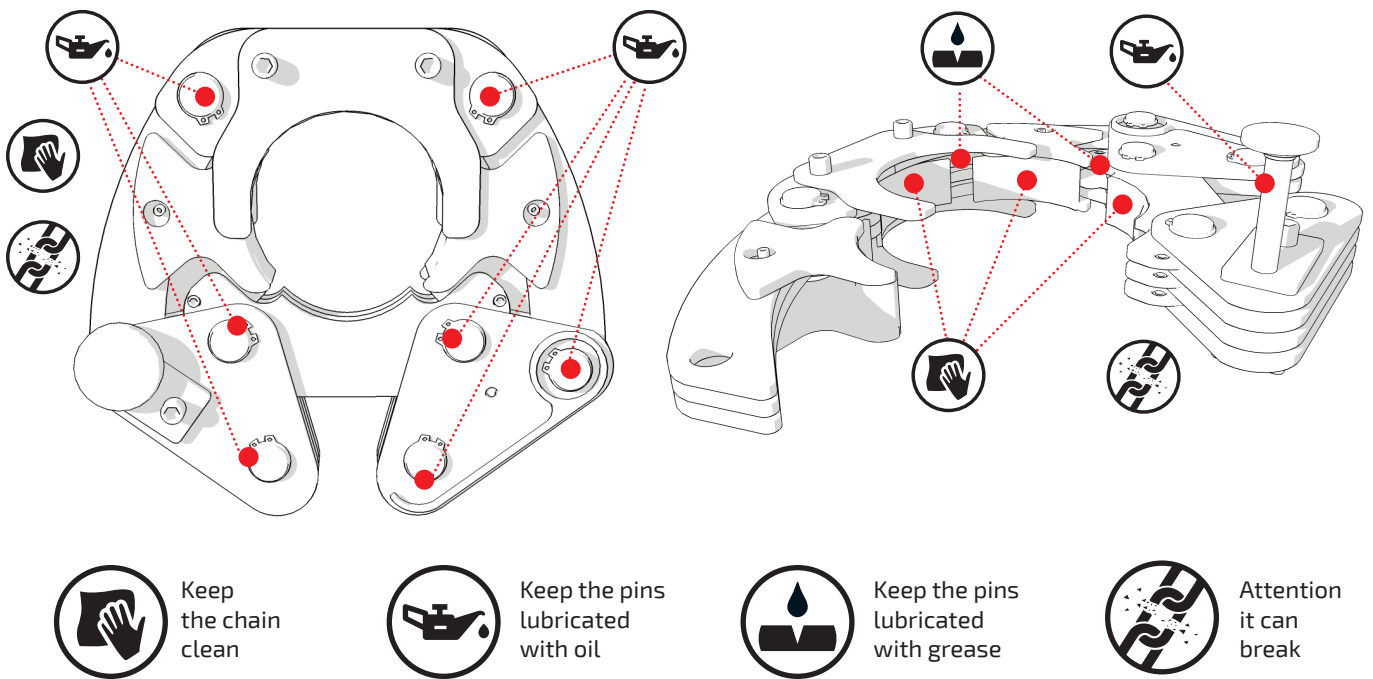

INSTALLATION - PIPE PREPARATION

1 MEASURE

Pipe Outside Diameter (mm/inch)	A mm/ inch	D (mm/inch)	L (mm / inch)
15 / 1/2"	20 / 13/16"	20 / 13/16"	60 / 2 3/8"
28 / 1"	23 / 15/16"	20 / 13/16"	66 / 2 5/8"
35 / 1 1/4"	26 / 1"	20 / 13/16"	72 / 2 13/16"
42 / 1 1/2"	30 / 1 3/16"	40 / 1 9/16"	100 / 5 1/2"
54 / 2"	35 / 1 3/8"	40 / 1 9/16"	110 / 4 5/16"
76 / 2 3/4"	55 / 2 3/16"	60 / 2 3/8"	170 / 6 11/16"
89 / 3 1/2"	60 / 2 3/8"	60 / 2 3/8"	180 / 7 1/16"
108 / 4"	75 / 2 15/16"	60 / 2 3/8"	210 / 8 1/4"

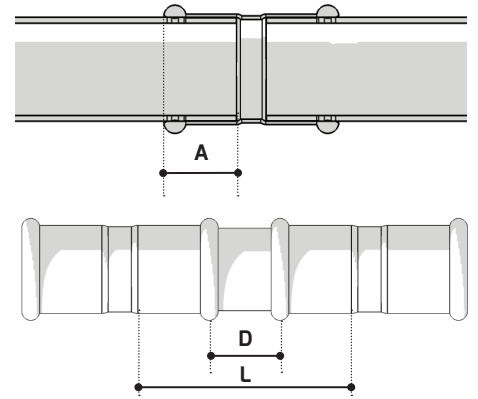

A = Insertion Depth
D = Minimum Distance
L = Minimum Pipe Length Tube

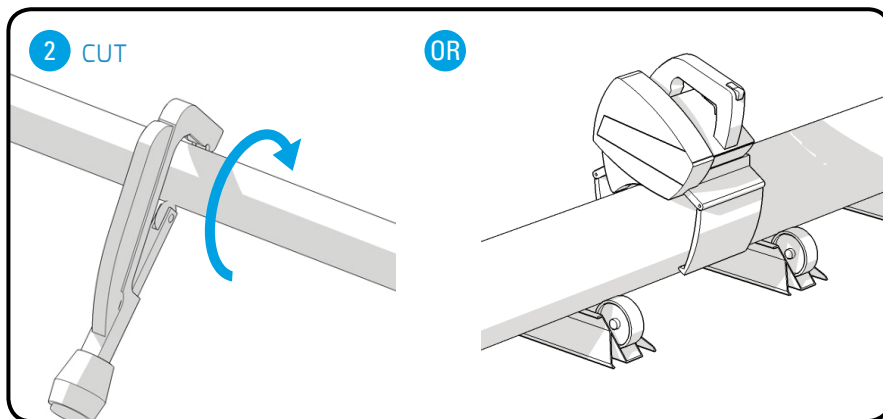

2 CUT

OR

Ø 15-54 mm 2810 0040 00

110/120V 2810 0640 80

Ø 76-108 mm 2810 0140 00

220/230V 2810 0540 80

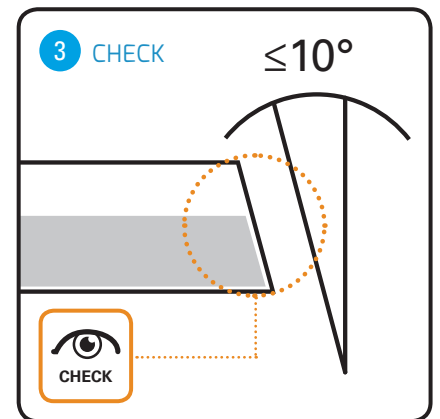

3 CHECK

≤10°

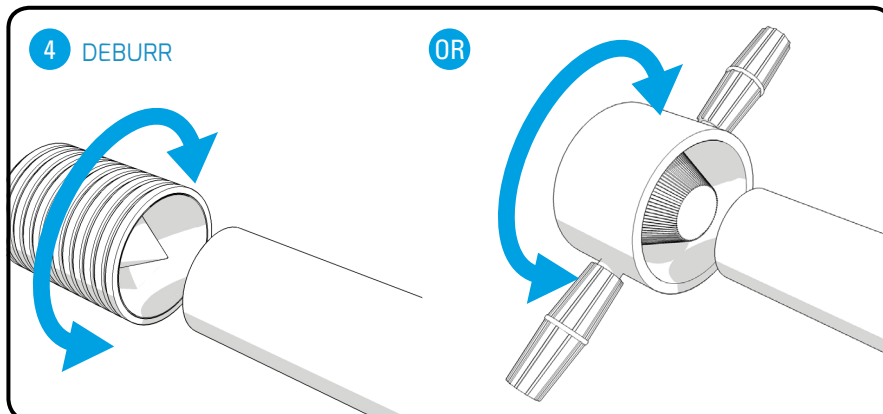

4 DEBURR

OR

Ø 15-54 mm 2810 0141 00

Ø 76 - 108 mm 2810 0641 00

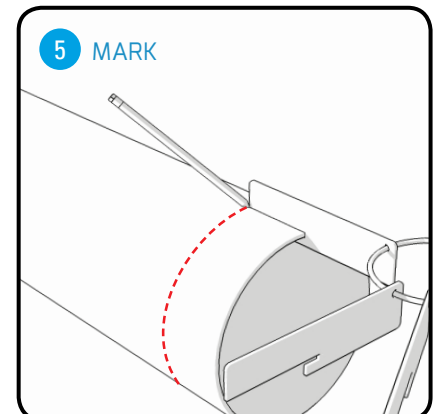

5 MARK

ALL

2812 0029 80

INSTALLATION - PRESS FITTING

Diameters 15 - 35 mm / 1/2" - 1 1/4"

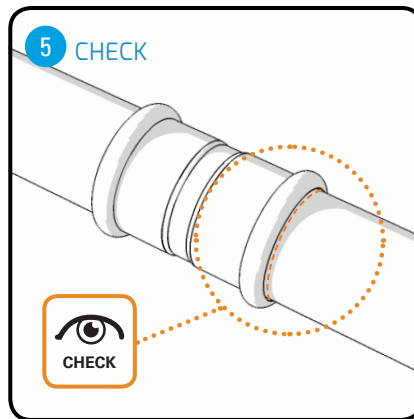
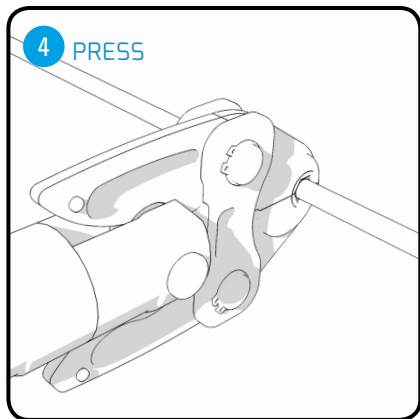
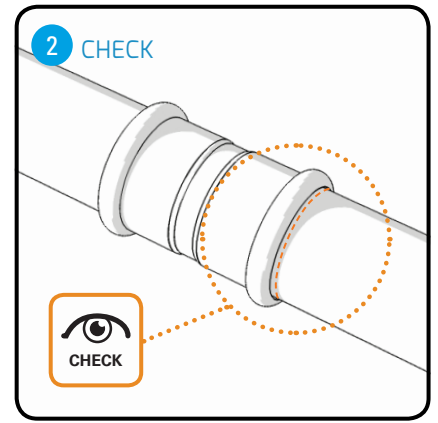
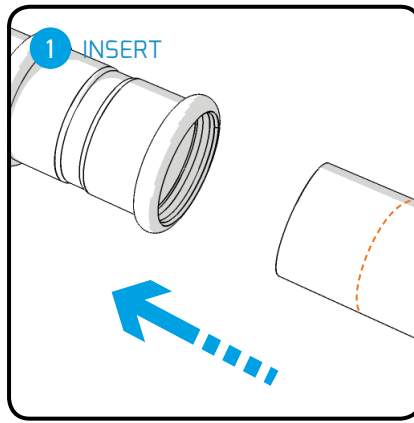
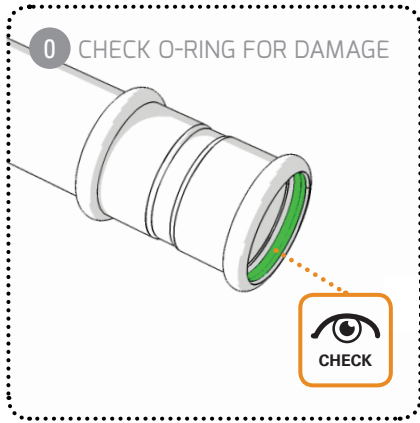

INSTALLATION - PRESS FITTING

Diameters 42 - 54 mm / 1 1/2" - 2"

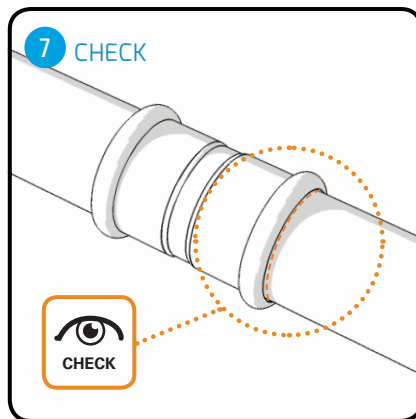
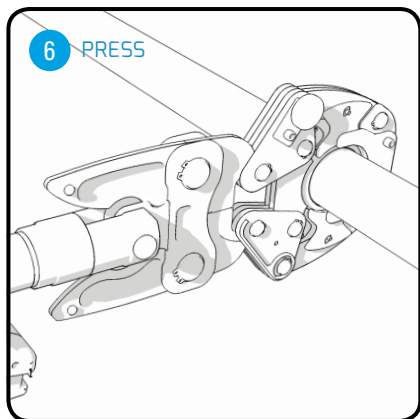
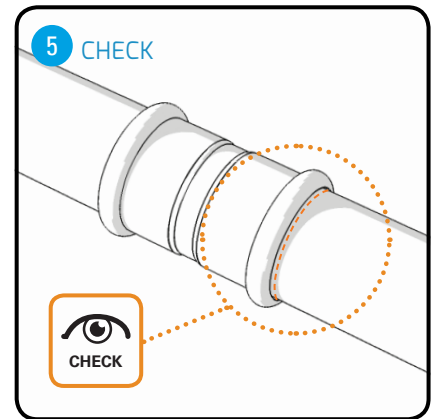
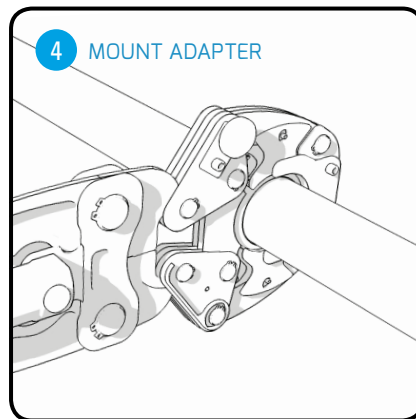
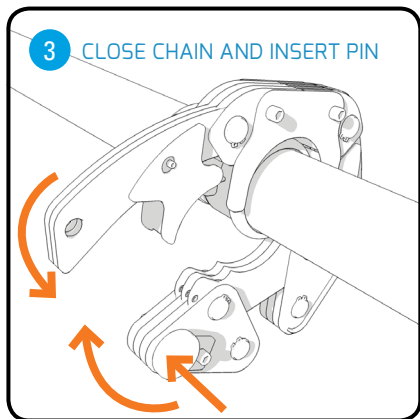
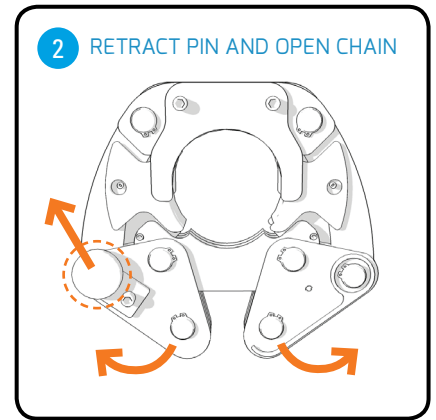
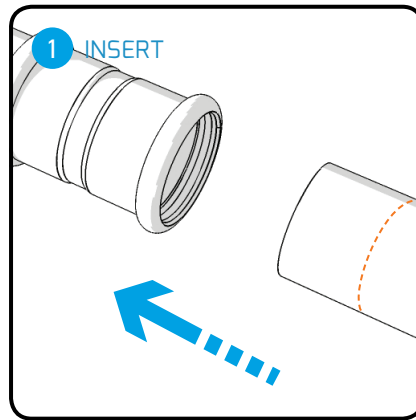

INSTALLATION - PRESS FITTING

Diameters 76 - 108 mm / 2 3/4" - 4"

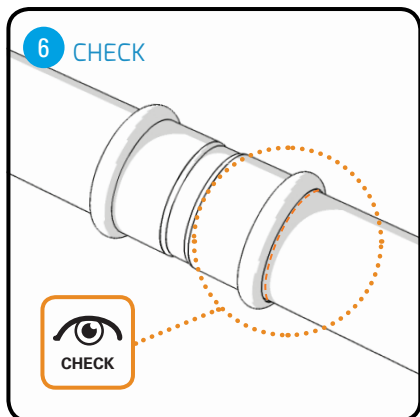
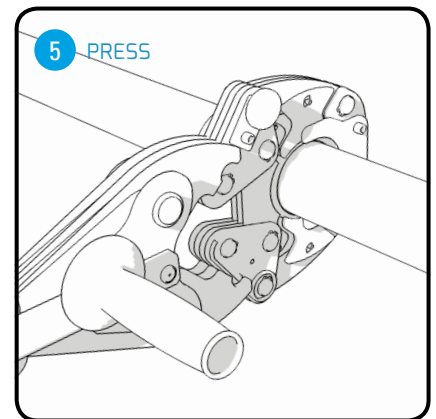
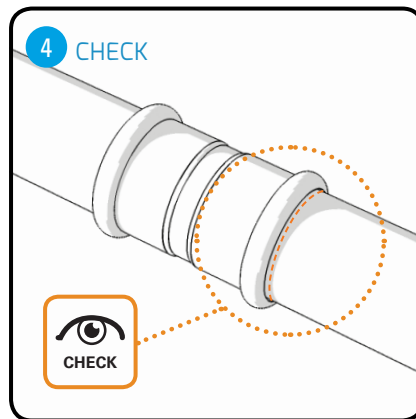
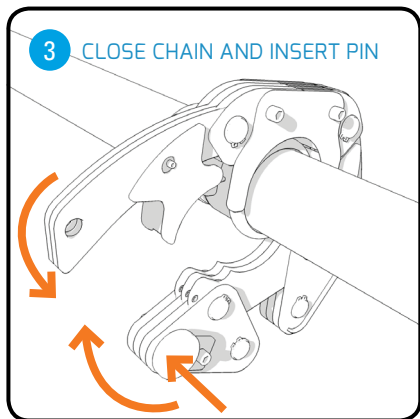
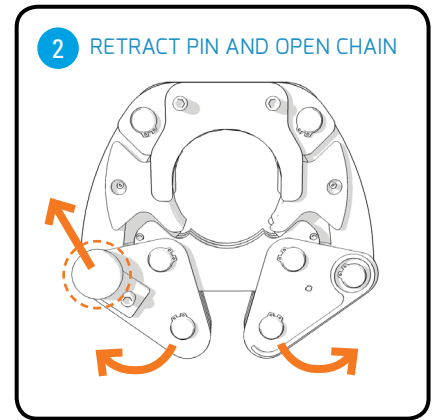
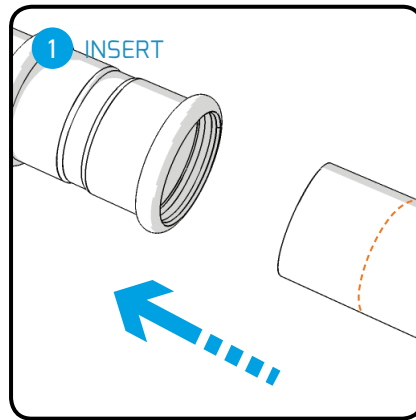
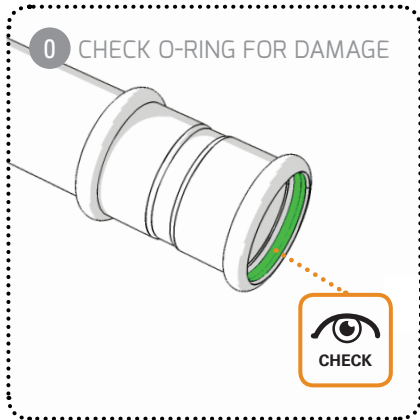

MINIMUM DISTANCES AND SPACE REQUIREMENTS FOR PRESSING

To carry out pressing correctly, there must be a minimum distance between the pipe and the building, and from pipe to pipe as shown in the tables below.

Minimum distances and space requirements D15 - D35 / 1/2" - 1 1/4"

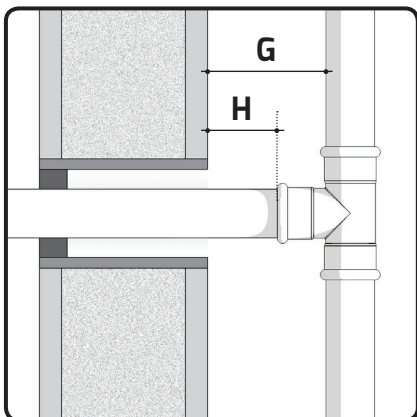
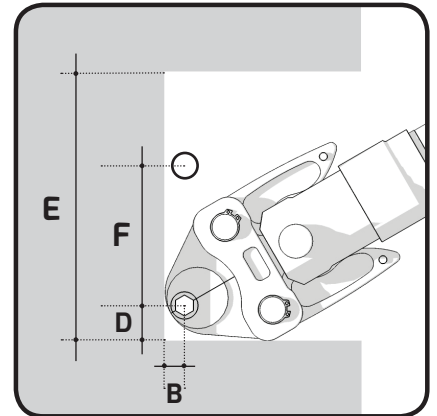
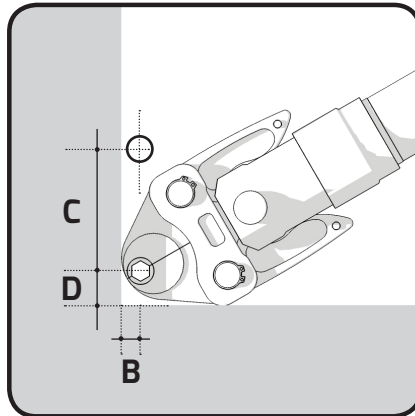
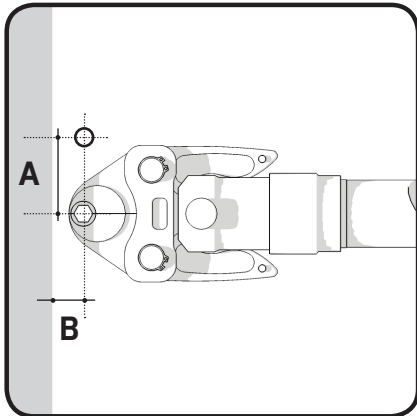

diameter	A	B	C	D	E	F	G	H
D15 - 1/2"	56 mm 2 1/4"	30 mm 1 1/8"	75 mm 3"	35 mm 1 3/8"	155 mm 6 1/8"	95 mm 3 3/4"	60 mm 2 3/8"	40 mm 1 5/8"
D28 - 1"	82 mm 3 1/4"	40 mm 1 5/8"	90 mm 3 1/2"	45 mm 1 3/4"	180 mm 7 1/8"	90 mm 3 1/2"	63 mm 2 1/2"	40 mm 1 5/8"
D35 - 1 1/4"	85 mm 3 3/8"	40 mm 1 5/8"	90 mm 3 1/2"	45 mm 1 3/4"	180 mm 7 1/8"	90 mm 3 1/2"	66 mm 2 5/8"	40 mm 1 5/8"

Minimum distances and space requirements D42 - D108 / 1 1/2" - 4"

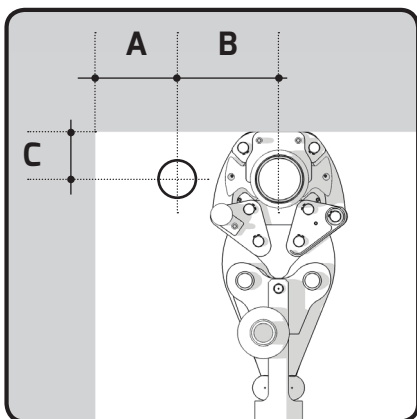

diameter	A	B	C
D42 - 1 1/2"	150 mm 5 7/8"	150 mm 5 7/8"	110 mm 4 3/8"
D54 - 2"	150 mm 5 7/8"	150 mm 5 7/8"	110 mm 4 3/8"
D76 - 2 3/4"	170 mm 6 3/4"	210 mm 8 1/4"	170 mm 6 3/4"
D89 - 3 1/2"	190 mm 7 1/2"	260 mm 10 1/4"	190 mm 7 1/2"
D108 - 4"	200 mm 7 7/8"	320 mm 12 5/8"	280 mm 11"

